

ARK 5.1-25.6XH-A1 High Voltage Battery System

User Manual (V1.0)



Download
Manual

Shenzhen Growatt New Energy Co., Ltd
4-13/F, Building A, Sino-German(Europe) Industrial Park,
Hangcheng Ave, Bao'an District, Shenzhen, China

T +86 755 2747 1942
E service@ginverter.com
W www.ginverter.com

GR-UM-242-A-01

Contents

About this Document

This document describes the installation, electrical connection, operation, commission, maintenance and troubleshooting of ARK 5.1-25.6XH-A1 Battery System (hereafter simply put ARK XH-A1). Before installing and operating ARK XH-A1 system, ensure that you are familiar with product features, functions, and safety precautions provided in this document.

| Symbol | Description |
|--|---|
|  WARNING | Indicates a potentially hazardous situation, if not avoided, could result in serious injury or death. |

1 Product Overview

- 1.1 Intended Use
- 1.2 Appearance
- 1.3 Working Principle and Function

2 Safety

- 2.1 Basic security
- 2.2 Safety Precautions
- 2.3 Warning Labels
- 2.4 Emergency Responses

3 Storage and Transportation

- 3.1 Storage Requirements
- 3.2 Transportation Requirement

4 Installation

- 4.1 Basic Installation Requirements
- 4.2 Installation Required Tools
- 4.3 Installation Procedures
- 4.4 Electrical Connection

5 Power on/off Battery system

- 5.1 Power on Battery system
- 5.2 Power off battery system

6 Maintenance Guide

- 6.1 Preparation
- 6.2 Battery pack or high voltage controller replacement
- 6.3 System Failure Information List and Troubleshooting Suggestions

7 Technical Specifications

- 7.1 ARK XH-A1 (high voltage system)
- 7.2 BDC 95045-A1 (High voltage controller)
- 7.3 ARK 2.5H-A1 (battery pack)

Appendix I

1 Product Overview

1.1 Intended Use

The entire ARK XH-A1 high-voltage energy storage system includes a BDC 95045-A1 (High voltage controller) and multiple ARK 2.5H-A1 (battery packs, Number of series less than 10).

Each ARK 2.5H-A1 consists of 50Ah cells which form 51.2V voltage battery pack via one parallel and sixteen serial connections (1P16S). Two to ten ARK 2.5H-A1 can be connected in serial and extend the capacity and power of energy storage system.

The ARK XH-A1 battery system powers the loads through hybrid inverter (It can be equipped with single-phase or three-phase, the following is just an example) at nighttime without solar; when solar becomes available during daytime, solar energy powers the loads as a priority and store residual solar power into the ARK XH-A1 battery system.

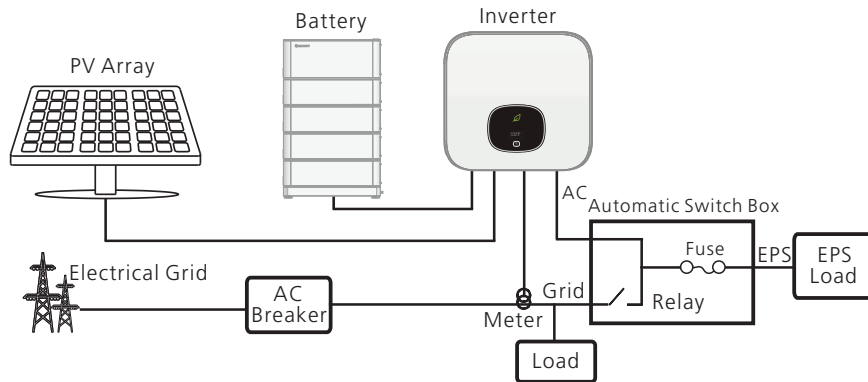

Fig 1.1: System diagram of ARK XH-A1 High voltage battery system

1.2 Appearance

1.2.1 BDC 95045-A1 (High voltage controller)

BDC 95045-A1 (High voltage controller) is composed of battery control unit (BCU), Power control units, relay, DC breaker, power supply and communication terminals. The appearance of the product is shown as below.

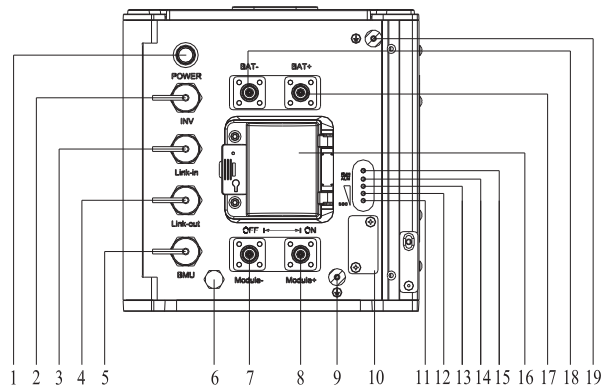

Fig 1.2: Schematic diagram of power panel

| Location | Port | Function | |
|----------|-----------------------|---|---|
| 1 | POWER | Wake up battery. | |
| 2 | INV | Port for communication with hybrid inverter. | |
| 3 | Link-in | Battery system in parallel communication input interface. | |
| 4 | Link-out | Battery system in parallel communication output interface. | |
| 5 | BMU | Communication with the battery module. | |
| 6 | Pressure relief valve | Pressures inside is released via the vent. | |
| 7 | Module- | Connect to the negative power terminal of the battery module. | |
| 8 | Module+ | Connect to the positive power terminal of the battery module. | |
| 9 | ⊕ | Ground terminal, connect to the battery module. | |
| 10 | USB interface | USB interface. | |
| 11 | LED1 | Blue, 0%-25%SOC. | |
| 12 | LED2 | Blue, 26%-50%SOC. | |
| 13 | LED3 | Blue, 51%-75%SOC. | |
| 14 | LED4 | Blue, 76%-100%SOC. | |
| 15 | LED5 | RUN | Yellow Run light indicates normal operation. |
| | | ALM | Red ALM light indicates failure or protection status. |
| 16 | Breaker | Breaker to turn on/off the whole battery system | |
| 17 | BAT+ | The positive output from battery system to the hybrid inverter. | |
| 18 | BAT- | The negative output from battery system to the hybrid inverter. | |
| 19 | ⊕ | Ground terminal, connect to the hybrid inverter. | |

Dimension (unit: mm)

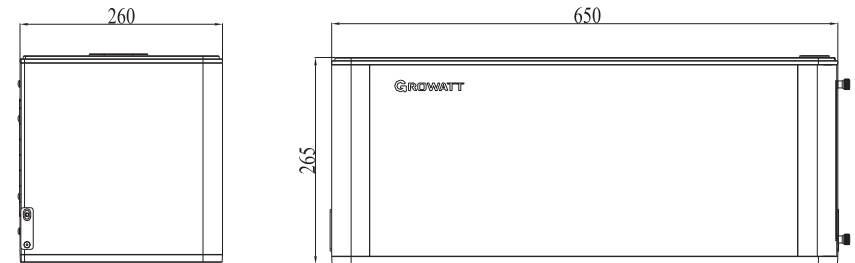

Fig 1.3: Dimension of BDC 95045-A1

1.2.2 ARK 2.5H-A1 (battery pack)

ARK 2.5H-A1 consists of battery module (including cell and mechanical parts), Battery management unit (BMU) as well as power and communication terminals. Product appearance is shown as below.

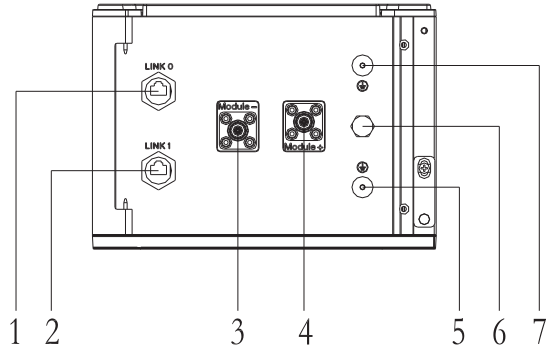

Fig 1.4: Schematic diagram of power panel

| Location | Port | Function |
|----------|-----------------------|--|
| 1 | Link0 | Communicate with the previous module. |
| 2 | Link1 | Communicate with the next module. |
| 3 | Module- | Power terminal connected to the negative terminal of the module. |
| 4 | Module+ | Power terminal connected to the positive terminal of the module. |
| 5 | ⊕ | Ground terminal, connect to the next module. |
| 6 | Pressure relief value | Pressures inside is released via the vent. |
| 7 | ⊕ | Ground terminal, connect to the pervious module. |

Dimension (unit: mm)

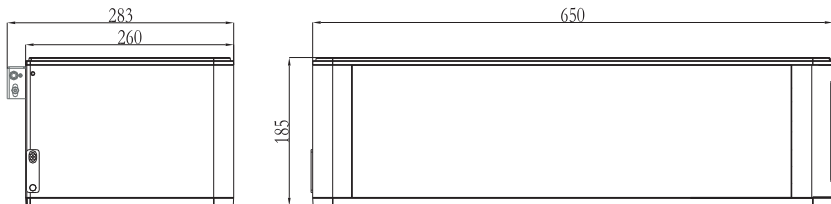

Fig 1.5: Dimension of ARK 2.5H-A1

(The depth dimension is 283mm when wall-mount installation is selected)

1.3 Working Principle and Function

The ARK XH-A1 high voltage battery system is composed of a High voltage controller BDC 95045-A1 and battery packs ARK 2.5H-A1 in series. It contains electrochemical batteries, battery control units, Power control units, battery management units, power and signal terminals, and mechanical parts.

Compared with other battery systems, it has better charging and discharging performance, higher charging and discharging efficiency, more accurate status monitor, longer cycle life and less self-discharge loss.

A single cluster system can connect 2 to 10 PACKs in series to increase the capacity and power of the battery system; at the same time, it supports parallel connection of 2 to 4 clusters of battery systems. The entire battery system communicates with hybrid inverter through RS485 communication, and the operation stability is high.

➤ Monitoring: voltage, current and temperature detection of both single cells and battery system.

➤ Protection and Alarm: protection and alarm when overvoltage, under voltage, over current, over-temperature or under temperature occurs. See Appendix I for the details.

➤ Report: report all alarm and status data to hybrid inverter.

➤ Series connection: support two to ten battery packs in Series connection.

➤ Parallel connection: support two to four battery clusters in parallel.

➤ Balance function: passive balance function.

➤ Power failure triggered by fault: 15 minutes after the battery system and hybrid inverter communication is disconnected or after under-voltage protection.

2 Safety

When installing or using a battery system, the safety information contained in this section must always be followed. For safety reasons, it is the installer's responsibility to be familiar with this manual and all warnings before installation.

2.1 Basic security

The battery system has been designed and tested in accordance with strict rules with international safety certification requirements. Before any installation or use of the battery system, please read all safety instructions carefully and always follow the relevant rules. Growatt is not responsible for any consequences resulting from violation of the following regulations:

- Damage occurred during transportation.
- Incorrect transportation, storage, installation and use, or customer fails to convey the correct information about transportation, storage, installation and use to terminal customers.
- Non-professional installation.
- Failure to obey the rules of this operation instructions and safety precautions in this document.
- Unauthorized modifications or removal of the software package.
- The product's tamper label is damaged or the product lacks any parts (except authorized disassembly parts).
- Operation in extreme environments which are not allowed in this document.
- Repair, disassemble, or change PACKs without authorization and cause failure.
- Damage to shell labels or modifies date of production.
- Battery packs fail to be charge for more than six months.
- Damages due to force majeure (such as lightning, earthquakes, fire, and storms).
- Warranty expiration.

2.2 Safety Precautions





2.2.1 Environmental requirements

- Do not expose the battery to temperature above 50°C or heat sources.
- Do not install or use the battery in wet locations, moisture, corrosive gases or liquids, such as bathroom.
- Do not expose the battery to direct sunlight for extended periods of time.
- Place battery in safe place away from children and animals.
- Battery power terminals shall not touch conductive objects such as wires.
- Do not dispose the batteries in fire, which may cause an explosion.
- The battery system shall not come in contact with liquids.

2.2.2 Operation Precautions

- Do not touch the battery system with wet hands.
- Do not disassemble the battery system without permission.
- Do not crush, drop or pierce the battery pack and high voltage controller.
- Dispose the batteries according to local safety regulations.
- Store and recharge battery in accordance with this manual.
- Ensure the connection of ground wire reliable.
- Remove all metal objects such as watches and rings that could cause a short-circuit before installation, replacement and maintenance.
- The system should be installed, repaired, replaced or maintained by skilled person or instructed person
 - + Skilled person
 - Person with relevant education and experience to enable him or her to perceive risks and to avoid hazards which the equipment can create .
 - Note 1 to entry: Such person has access to restricted access areas [SOURCE: IEC 60050-195:1998, 195-04-01, Modified – The word “(electrically)” has been deleted from the term, and “electricity” has been replaced by “the equipment” in the definition. The note has been added.]
 - + Instructed person
 - Person adequately advised or supervised by skilled persons to enable him or her to perceive risks and to avoid hazards which the equipment can create
 - Note 1 to entry: Such person has access to restricted access areas
 - Note 2 to entry: Examples of activities performed by an instructed person can be found in IEC 61140:2001, Clause 8.
 - [SOURCE: IEC 60050-195:1998, 195-04-02, Modified – The word “(electrically)” has been deleted from the term, and the notes have been added.]
- When storing or handling batteries, do not stack batteries without package.
- Do not broke the battery, the released electrolyte may be toxic and is harmful to skin and eyes.
- Packaged batteries should not be stacked more than specified number stipulated on the packing case.
- Do not use damaged, failed or deformed batteries, which may lead to high temperature or even dangerous accidents. Continued operation of damaged battery may result in electrical shock, fire or even worse.

2.3 Warning Labels

| Symbols | Description |
|---|--|
|  | Operation after 5 minutes after disconnecting the power supply (including disconnect/connect power wiring) |
|  | Do not dispose in trash |
|  | Lithium ion battery can be recycled |
|  | Certification in European union area |
|  | Electric shock hazard |

| Symbols | Description |
|---------|---|
| | Explosive gas |
| | May leak corrosive electrolyte |
| | Heavy enough to cause severe injury |
| | Keep the Pack away from children |
| | Make sure the battery polarity well connected |
| | Do not expose to fire |
| | Operate as the Manual |

| Lithium Ion Battery | |
|-------------------------------|---------------|
| Model | ARK 2.5H-A1 |
| Nominal Voltage | 51.2V |
| Nominal/Rated Capacity | 50Ah/45Ah |
| Nominal/Rated Energy | 2560Wh/2300Wh |
| Rated Current | 25A |
| Ingress Protection | IP 65 |
| Operating Ambient Temperature | -10°C ~ +50°C |
| | |

Fig 2.1: Nameplate

WARNING

- Do not disassemble or alter the PACK to avoid heat ,explosion or fire.
- Do not use the PACK beyond specific conditions.It might cause heat generation ,damage,or deterioration of its performance.
- Do not throw,drop,hit,drive a nail in,stamp on the PACK.It may cause heat generation,explosion,or fire.
- In case of electrolyte leakage,keep leaked electrolyte away from contact with eyes or skin.immediately clean with water and seek help from a doctor.
- Do not put the PACK into a fire.Do not use it or leave it on a place near fire,heaters,or high temperature sources.It may cause over temperature,explosion or fire.
- Do not submerge the PACK in water,or wet the product.It may cause heat generation,explosion ,or fire.
- Do not reversely connect the PACK positive(+)and negative(-)terminal.
- Do not short circuit by letting the PACK terminals(+and -)contact a wire or any metal.
- The unit is heavy enough to cause severe injury.
- Keep out of reach of children or animals.

Fig 2.2: Label

| ARK High Voltage Battery System | |
|-------------------------------------|---|
| System Model/ | <input type="checkbox"/> ARK 5.1XH-A1/ 360-950 d.c.V/ 2.5kWh/5.12kWh <input type="checkbox"/> ARK 7.6XH-A1/ 360-950 d.c.V/ 3.75kWh/7.68kWh <input type="checkbox"/> ARK 10.2XH-A1/ 360-950 d.c.V/ 5kWh/10.24kWh <input type="checkbox"/> ARK 12.8XH-A1/ 360-950 d.c.V/ 6.25kWh/12.8kWh <input type="checkbox"/> ARK 15.3XH-A1/ 360-950 d.c.V/ 7.5kWh/15.36kWh <input type="checkbox"/> ARK 17.9XH-A1/ 400-950 d.c.V/ 8.75kWh/17.92kWh <input type="checkbox"/> ARK 20.4XH-A1/ 550-950 d.c.V/ 10kWh/20.48kWh <input type="checkbox"/> ARK 23.0XH-A1/ 580-950 d.c.V/ 11.25kWh/23.04kWh <input type="checkbox"/> ARK 25.6XH-A1/ 640-950 d.c.V/ 12.5kWh/25.6kWh |
| High Voltage Controller Model | BDC 95045-A1 |
| Protective Class | I |
| Max. Current | 21A |
| Total/Rated Capacity | 50Ah/45Ah |
| Ingress Protection | IP65 |
| Operation Ambient Temperature | -10°C ~ +50°C |
| | |

Fig 2.3: Nameplate

WARNING

The performance will be limited when the temperature is below 0°C.

2.4 Emergency Responses

Manufacturer takes foreseeable risk scenarios into consideration and is designed to reduce hazards and dangers. However, if the following situation occurs, do as below:

| Situation Occurs | Description and action need |
|------------------|---|
| Leakage | Avoid touch of leaking liquid or gas. If you touch the leaking electrolyte, do as below immediately. Inhalation: Evacuate the contaminated area, and seek medical help. Eye contact: Rinse eyes with flowing water for 15 minutes, and seek medical help. Skin contact: Rinse contacted area thoroughly with soap and water, and seek medical help. Ingestion: Vomiting, and seek medical help. |
| On fire | It's hard for battery system ignite spontaneously. If the battery has caught a fire, do not try to extinguish the fire but evacuate people immediately. |
| Wet Packs | If the battery system is soaked or submerged in water, do not access it. Contact Growatt or distributors immediately for technical assistance. |
| Damaged shell | Damage to the shell is very dangerous, so special attention must be paid. They are no longer suitable for use and may be dangerous to personnel. If the battery case is damaged, please stop using it and contact Growatt or a distributor. |

3 Storage and Transportation

3.1 Storage Requirements

- Place the product follow the identification on the packing case during storage.
- Do not put the product upside down or sidelong.
- The defective product needs to be separated from other product.
- The storage environment requirements are as follows:
 - Install the product in a dry and clean place with proper ventilation.
 - The storage temperature for a short week(7 days) is between -30°C to 60 C.
 - If you store the product over a long period of six months, the storage temperature is between-20°C to 45°C, relative humidity: 5%~95%RH.
 - Place the product away from corrosive and organic substances (including gas exposure).
 - Free from direct exposure to sunlight and rain.
 - At least two meters away from heat sources (such as a radiator) .
 - Free from exposure to intensive infrared radiation.



Notice

If the battery pack is not used for more than six months, a complete charge-discharge cycle is required every six months.

3.2 Transportation Requirement

Battery pack has been certified in UN38.3 (Section 38.3 of the sixth Revised Edition of the Recommendations on the Transport of Dangerous Goods: Manual of Tests and Criteria) and SN/T 0370.2-2009 (Part 2: Performance Test of the Rules for the Inspection of Packaging for Exporting Dangerous Goods). Battery pack is classified as category 9 dangerous goods.

- The battery pack shall not be transported with other inflammable, explosive or toxic substances
- Ensure the original Package and label complete and recognizable.
- Prohibit direct exposure to sunlight, rain, condensing water caused by temperature difference and mechanical damages.
- Prohibit to pile up more than six battery pack.
- There will be a drop in capacity during transportation and storage.
- Transportation temperature is between-20°C to 45°C, relative humidity: 5%~95%RH.

Installation 4



WARNING

- Ensure to read the Guidance before installation in order to understand product information and safety cautions;
- Operators should be well trained technicians and fully understand the whole photovoltaic system, grid network, battery system, working principle and national regional standards;
- Installers must use insulating tools and wear safety equipment.
- Device damages caused by failure to comply with storage, transportation, installation and use requirements specified in Guidance are not covered by Warranty.
- Do not install or use battery near explosive or inflammable substances. are not covered by Warranty.
- Use battery in well-ventilated environment with temperature ranging from -10°C to 45°C. For outdoor installation, build sun & rain shade to avoid direct sunlight and rain exposure.
- Maintain a minimum level of dust and dirt in the environment.
- Do not install battery in highly humid area such as bathroom.
- Please make sure that all battery pack connected in series are from the same batch, the same model and the same manufacturer; do not mix old batteries with new batteries. A battery pack that does not exceed 200 cycles is defined as a new battery.

4.1 Basic Installation Requirements

- The battery system can be installed indoors or outdoors. The following conditions are allowed:

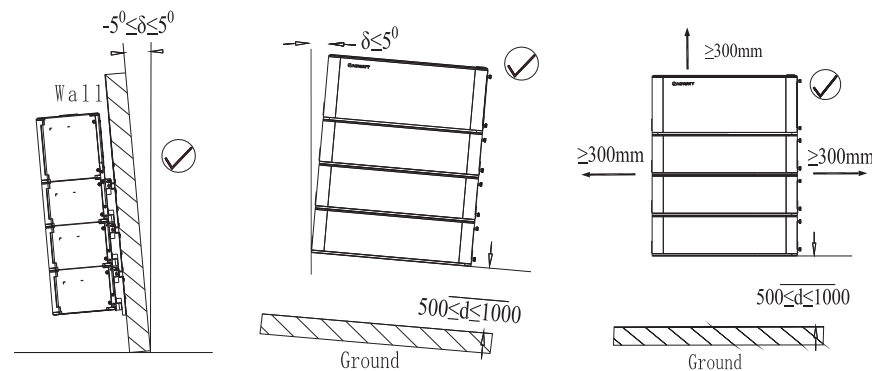

Fig 4.1:Acceptable wall mounted installation

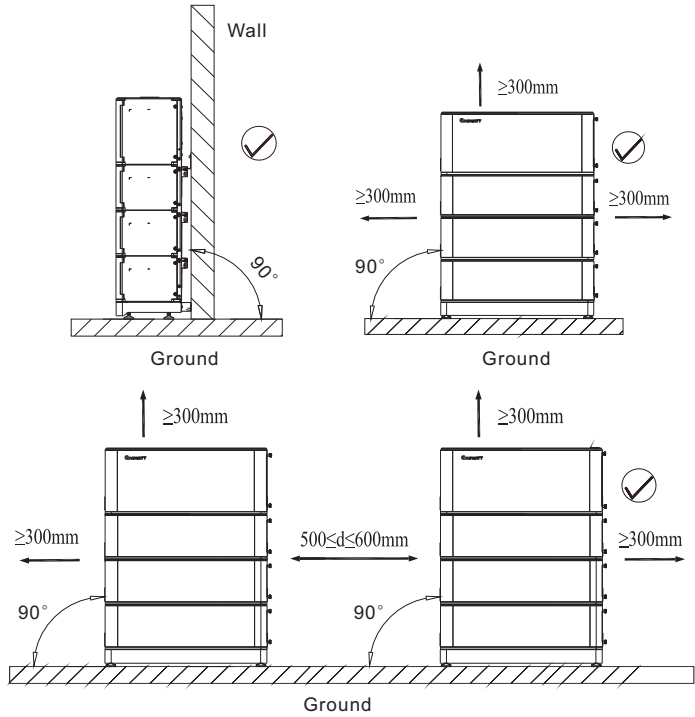



Fig 4.2: Acceptable floor standing installation

| | |
|--|---|
|  WARNING | <p>Do not place the battery pack upside down.</p> |
|--|---|

➤ When installing outdoors, it is necessary to install sunshades and rain shelters to avoid direct exposure to sunlight and rain.

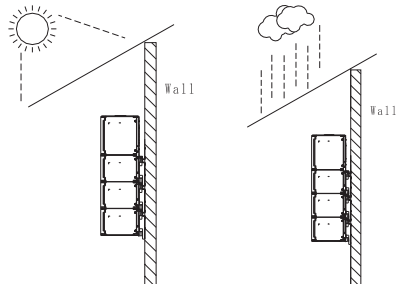









Fig 4.3: Sunshades and rain shelters

4.2 Installation Required Tools

The following tools are required to install the battery system:

| | | |
|---|---|---|
|  Drill |  Screw Driver |  Wrench |
|  Pencil |  Tap Measure |  Multimeter |

It is recommended to wear the following safety gear when dealing with the battery system.

| | | |
|--|--|---|
|  Insulated Glove |  Safety Goggle |  Safety Shoes |
|--|--|---|

4.3 Installation Procedures

4.3.1 Pre-installation Check

- Check the PACK package before open it. If any abnormality is detected, do not open the Package and contact your distributor.
- Check the quantity of all parts inside according to the package list. If there is any part missing or damaged, please contact your distributor.

4.3.1.1 Check the BDC 95045-A1

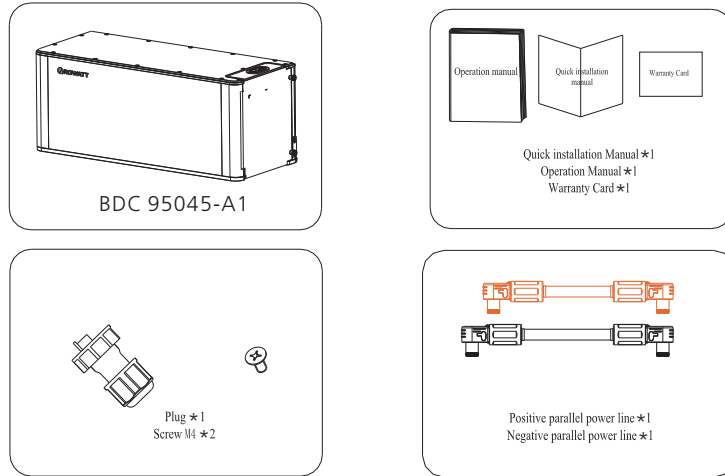

Fig 4.4: components and parts of BDC 95045-A1

4.3.1.2 check the ARK XH Cable

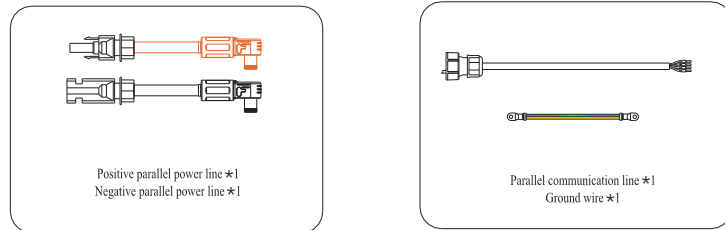

Fig 4.5: components and parts of ARK XH Cable

4.3.1.3 Check the ARK 2.5H-A1

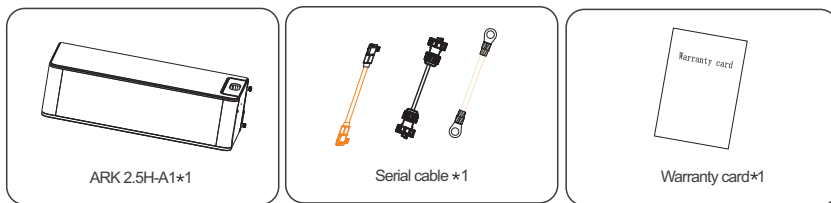

Fig 4.6: components and parts of ARK 2.5H-A1

4.3.1.4 Check the wiring of ARK 2.5H-A1 series cable

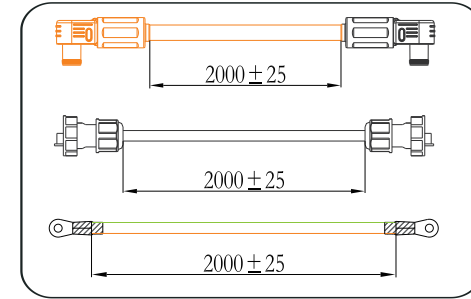

Fig 4.7: components and part of ARK 2.5H-A1 series cable

4.3.1.5 Check the wiring of BDC 95045-A1 to the hybrid Inverter

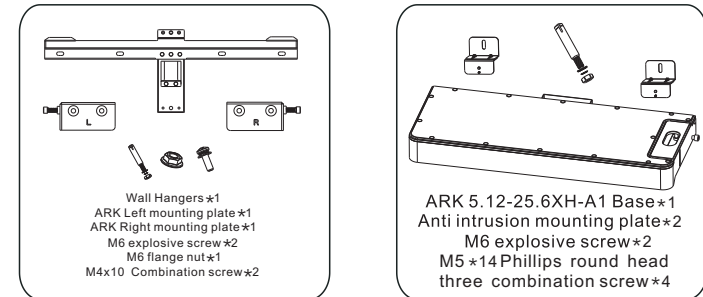

Fig 4.8: Optional installation accessories



Notice

- The High voltage controller (BDC 95045-A1) and the battery pack (ARK 2.5H-A 1) are standard accessories, please be sure to purchase both, a battery system only needs a High voltage controller (BDC 95045-A1), battery pack (ARK 2.5H-A1) You can freely match the number within 2 to 10 .
- The battery base is only used for floor installation. The number of battery bases is matched according to the number of battery rows installed. If it is a row, only one battery base is required, and two rows are required two. And the wall bracket is only used for wall installation. The number of wall brackets are determined by the number of battery modules. The battery base and wall bracket are optional accessory, not standard accessory."
- If you want to install the same battery system in two lines, you need to purchase a series extension cable separately for connection.
- The installation method can be selected wall Mounted installation or floor standing installation, see Section 4.3.1.5.

4.3.2 Wall Mounted Installation

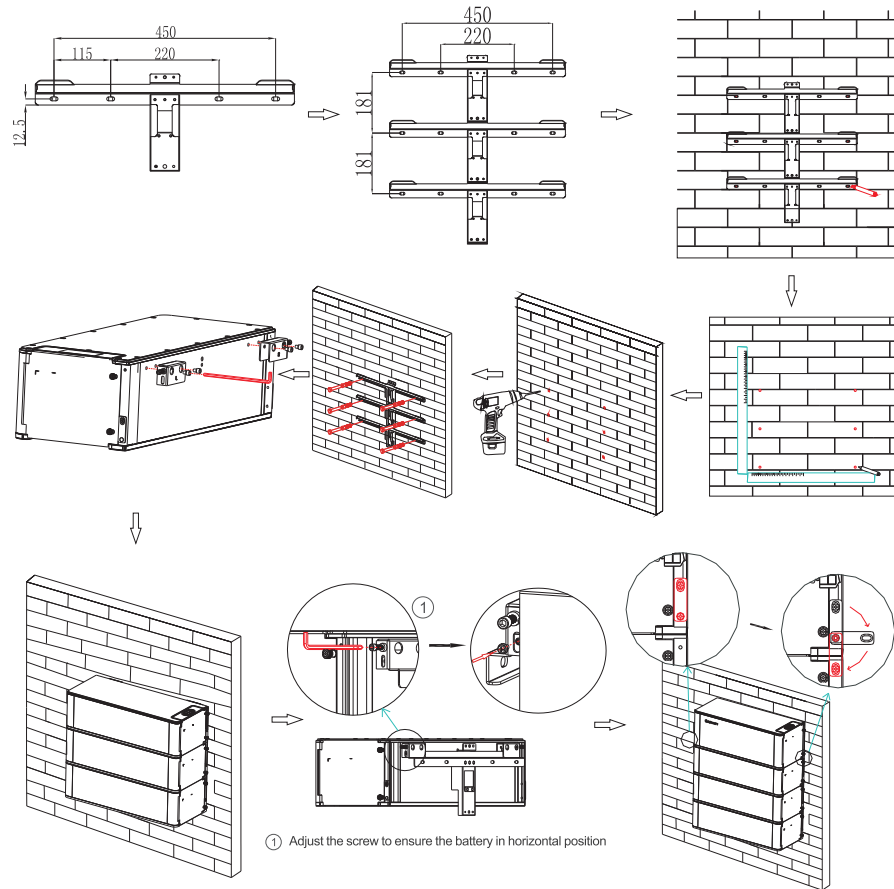

Fig 4.9: Multiple battery installation process with wall mount

- Step 1: Please make sure that the weight capacity of the wall should exceed 300kg.
- Step 2: Choose an alloy drill with a diameter of 8mm, and drill at least 50mm mounting holes in the wall. Clean the soil and insert the expansion tube into the hole, then screw in the screw to fix the wall mount.
- Step 3: Fix the battery on the wall mount from top to bottom, make sure that the battery will not shake, and then lock the safety screw.



Notice

- The number of wall-mounted installations should not exceed six (including High voltage controller).
- If there are more than six, please install them in two rows, and the spacing should be greater than or equal to 300mm.

4.3.3 Floor Standing Installation

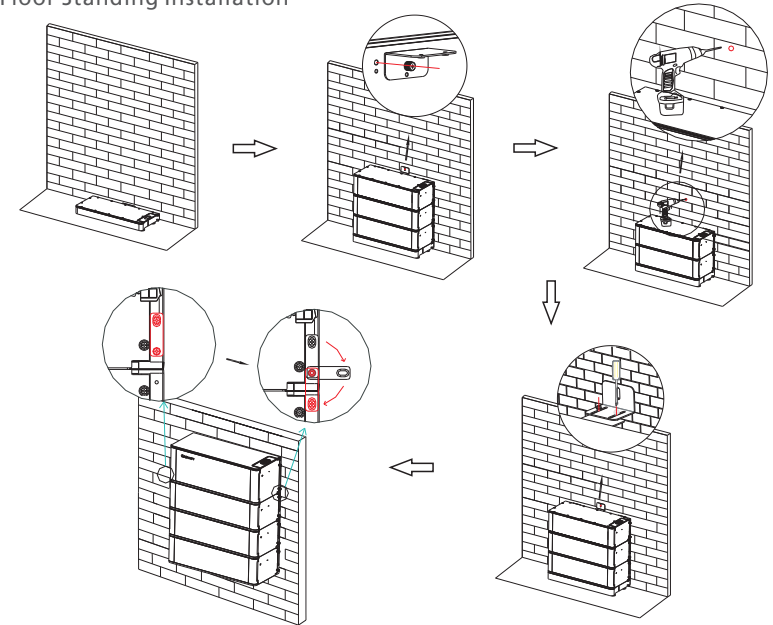

Fig 4.10: Multiple battery pack with base installation process

- Step 1: Choose an alloy drill with a diameter of 8mm and drill at least 50mm mounting holes on the wall. Clean the soil and insert the expansion tube into the hole, then screw in the screw to fix the wall mount.
- Step 2: Fix the battery on the wall bracket and the base from bottom to top, make sure the battery will not shake, and then lock the safety screw.



Notice

- For floor installation, we recommend that the number of the stacked battery modules is no higher than seven (including High voltage controller).
- If there are more than seven, please install them in two rows, and the spacing should be greater than or equal to 300mm.

4.4 Electrical Connection



WARNING

- Do not forget wear ESD wrist strap and gloves, safety gloves and goggles.

4.4.1 Communication port definition

| BDC 95045-A1 communication interface | | | MIN TL-XH Hybrid inverter (single phase) interface | | |
|--------------------------------------|------------------------|--------------|--|------------------------|------------|
| Silk screen | Terminal serial number | Definition | Silk screen | Terminal serial number | Definition |
| INV | 1 | WAKE-(W-) | SYS COM | 1 | BAT.EN- |
| | 2 | WAKE+(W+) | | 2 | BAT.EN+ |
| | 3 | CAN_H | | 3 | / |
| | 4 | CAN_L | | 4 | / |
| | 5 | GND | | 5 | / |
| | 6 | Null | | 6 | / |
| | 7 | RS 485_B (B) | | 7 | RS 485_B |
| | 8 | RS 485_A(A) | | 8 | RS 485_A |

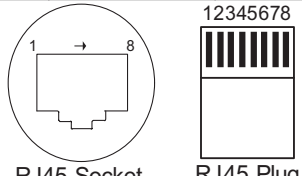

RJ45 Socket
RJ45 Plug
Pin assignments front view

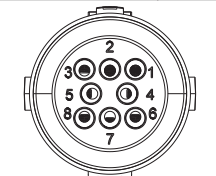

Pin assignments front view

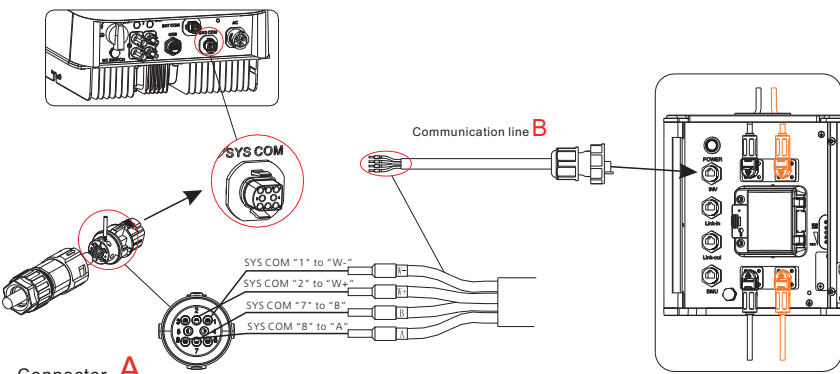

Connector **A**

Communication line **B**

SYS COM "1" to "W-"
SYS COM "2" to "W+"
SYS COM "7" to "B"
SYS COM "8" to "A"

| BDC 95045-A1 communication interface | | | MOD TL3-XH Hybrid inverter (three phase) interface | | |
|--------------------------------------|------------------------|--------------|--|------------------------|------------|
| Silk screen | Terminal serial number | Definition | Silk screen | Terminal serial number | Definition |
| INV | 1 | WAKE-(W-) | COM | 10 | BAT.EN- |
| | 2 | WAKE+(W+) | | 9 | BAT.EN+ |
| | 3 | CAN_H | | / | / |
| | 4 | CAN_L | | / | / |
| | 5 | GND | | / | / |
| | 6 | Null | | / | / |
| | 7 | RS 485_B (B) | | 8 | RS485B2 |
| | 8 | RS 485_A(A) | | 7 | RS485A2 |

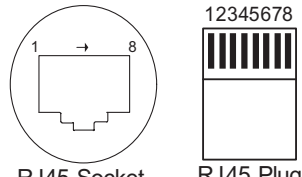

RJ45 Socket
RJ45 Plug
Pin assignments front view

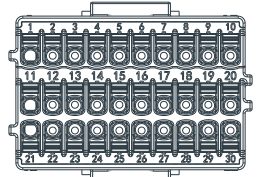

Pin assignments front view

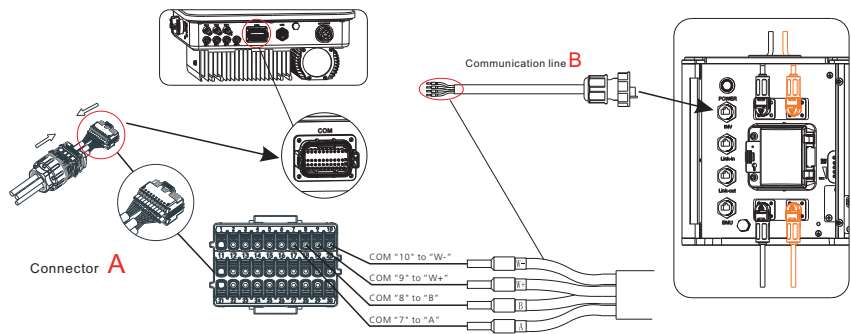

Connector **A**

Communication line **B**

COM "10" to "W-"
COM "9" to "W+"
COM "8" to "B"
COM "7" to "A"

4.4.2 System connection



Notice

- Before installing in series, make sure that the voltage difference of the battery pack must be less than or equal to 0.5V.
- When connecting the power line, it must be the same color terminal to connect and then use it together, otherwise there may be dangers such as short circuit on the side.
- A DC circuit breaker has been installed in the High voltage controller, It is not recommended to install a DC circuit breaker between the battery system and the hybrid inverter system, If you want to install a DC circuit breaker, do not operate the DC circuit breaker with power on, otherwise the machine may be damaged. And then you need to purchase it yourself according to the following specifications:
 - a. Voltage: 1000Vdc
 - b. Current: 63A

4.4.2.1 System connection diagram

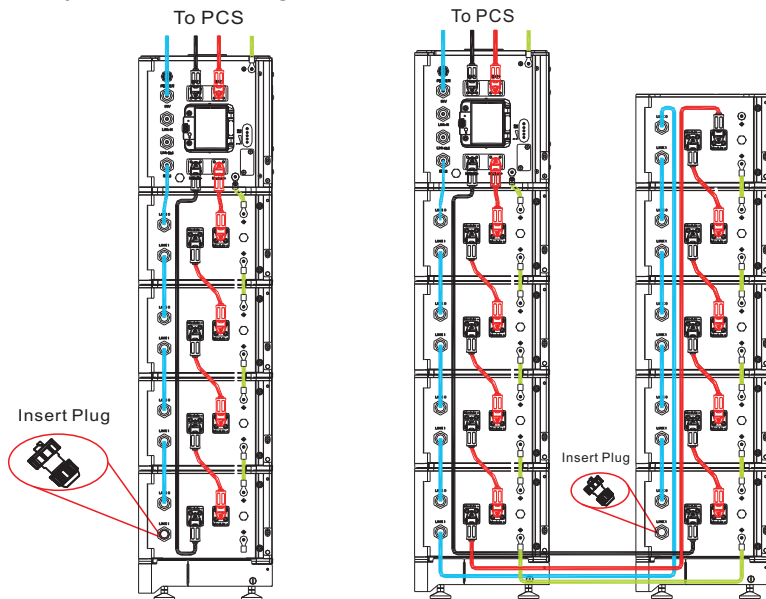

Fig 4.11: Single line installation

Fig 4.12: Two lines installation

Fig 4.11 Note:

The battery is not allowed to be installed in the running state, and all the RUN lights of battery modules should be off before installation.

To ensure system security, do not forget to install ground wire.

Don't forget to connect the communication plug of the last battery pack, otherwise it will cause system failure.

Fig 4.12 Note:

When installing in two rows, please purchase the extended serial cable, extended ground cable and extended communication cable between the two rows separately.

Don't forget to connect the communication plug of the last battery pack, otherwise it will cause system failure.

4.4.2.2 Electrical wiring connection

A. BDC 95045-A1 (High voltage controller) wiring

Step 1: Insert the power cable into the corresponding port, then there is click sound indicating the connection is ok.

Step 2: Insert the communication cable into the "INV port" and "BMU port", and then tighten the communication terminal clockwise. INV communication port is used for communication connection with hybrid inverter, BMU communication port is used for communication connection with battery pack.

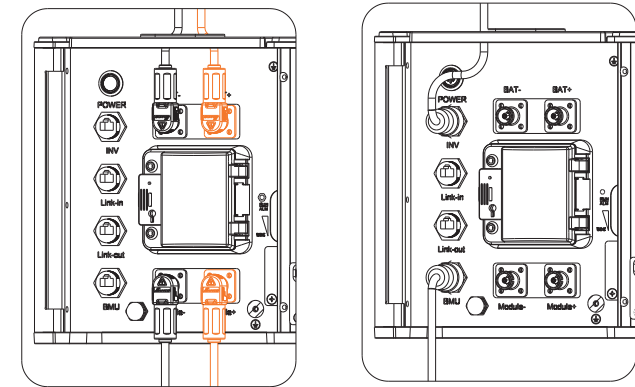

Fig 4.13: BDC 95045-A1 Electrical wiring connection diagram



Notice

- For a single cluster battery system, the "Link-in" and "Link out" port of the BDC 95045-A1 don't need to be connected, they are only used for parallel connection of the battery systems.
- Please pay attention to the connector color when connection the power line. Only the same color of the connector could be connected together.
- To ensure system security, do not forget to install ground wire.
- This area is a restricted access area, which is explained below:
 - area accessible only to electrically skilled persons and electrically instructed persons with the proper authorization.
 - note 1 to entry: An electrically skilled person is a person with relevant education and experience to enable him or her to perceive risks and to avoid hazards electricity can create.
 - note 2 to entry: An electrically instructed person is a person adequately advised or supervised by electrically skilled persons to enable him or her to perceive risks and to avoid hazards which electricity can create.

Power on/off Battery system 5

B.ARK 2.5H-A1(Battery module) wiring

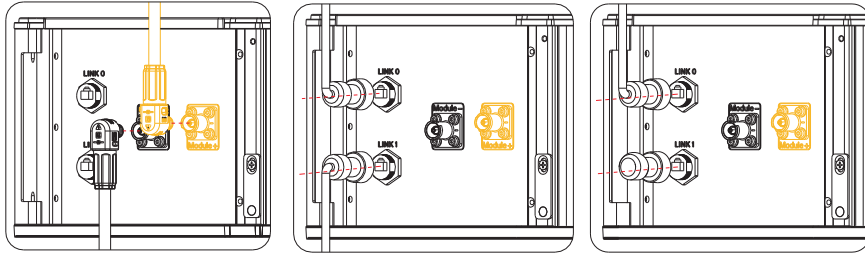

Fig 4.14: ARK 2.5H-A1 Electrical wiring connection diagram

Step 1: Insert the power cable into the corresponding port, then there is click sound indicating the connection is ok.

Step 2: Insert the communication cable into the "Link0 port" and "Link1 port", and then tighten the communication terminal clockwise.

Step 3: Insert a plug into the "Link1 port" of the last ARK 2.5H-A1(battery module). The plug is an annex of BDC 95045-A1 (High voltage controller).



Notice

- The battery module furthest from the BDC 95045-A1 (High voltage controller) is defined as the last battery module.
- Please pay attention to the connector color when connecting the power line. Only the same color of the connector could be connected together.
- The power lines between the battery modules are connected in series. Be careful not to short-circuit the battery modules during the connection process.



Notice

- The installation and use of batteries involve much specialized knowledge. Therefore, technicians should be given appropriate technical training and obtain operational certificates in compliance with local laws and regulations. Please ensure technicians have obtained training certificate before operation.
- Please stand on dry insulating objects and do not wear conductive material such as watches and necklace during operation. Insulated tools should be used.
- Do not contact any positions with potential difference.
- Prohibition sign should be hung on the battery: " Non - professionals, do not touch. "
- If any abnormalities occur during the startup phase, power off the PACK immediately. After problem confirmed, proceed again.
- Make sure the inverter is turned off before checking the PACK.

5.1 Power on Battery system

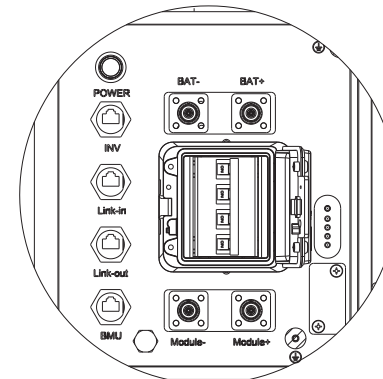
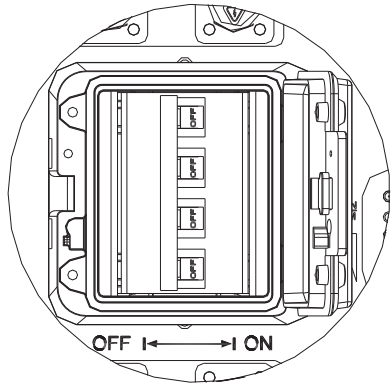

Fig 5.1

- Before turning on the battery system, please check whether the system wiring is properly connected, including the wiring to the hybrid inverter.
- Turn the DC breaker of the BDC 95045-A1 (High voltage controller) to "ON", then press the power button until the Battery Run light turn yellow, which means the battery system is powered on completely .

| Power on the PACK by pressing power button(t>5S) | | |
|--|---|--|
| Serial | Procedures | Acceptation criteria |
| 1 | Connect the battery and hybrid inverter | Make sure the wiring harnesses are well connected |
| 2 | Close the breaker of the battery system | Make sure the breaker is ON |
| 3 | Press POWER button for three to eight seconds. Observe the LED indication on panel. | 1. If both RUN/ALM and SOC lights turn on normally, PACK is powered on successfully. 2. If RUN/ALM light turns red, there is a failure and should solve it before power on again. |

5.2 Power off Battery system



➤ Turn the DC breaker of the BDC 95045-A1 (High voltage controller) to "Off" to turn off the entire.

Fig 5.2

6.1 Preparation

Before maintenance, please make sure that the battery system is powered off and the DC circuit breaker is off.

6.2 Battery pack or High voltage controller replacement

- Wear safety gloves.
- Open the breaker and power off the battery system.
- Disconnect power lines and communication lines of the battery system.
- Wall-mounting battery system: Uninstall the safety screws on both sides of the battery pack or High voltage controller. Lift up the battery pack or High voltage controller.
- Floor-standing battery system: Uninstall the safety screws on both sides of the battery pack or High voltage controller. Lift up the battery pack or High voltage controller.
- Put the battery pack or High voltage controller into the packing box according to the repair procedure and transport the battery pack or High voltage controller to the designated repair site.
- Install new battery pack or High voltage controller based on procedure specified in Section 4.

6.3 System Failure Information List and Troubleshooting Suggestions

| Error Indication | Error description | Error cause | Suggested actions |
|--------------------------|--------------------------------------|---|--|
| ALM | | | |
| * (ALM Light Flickers) | Discharge under voltage protection | Single cell voltage below the threshold for under-voltage protection. | There is over discharge risk. User should stop discharging and arrange recharge. |
| | Charge over voltage protection | Single cell voltage exceeding threshold for protection threshold. | 1. There is no safety threat; 2. User should stop charging. Wait for the battery system to automatically resolve the fault. |
| | External RS485 Communication failure | Communication loss between hybrid inverter and battery system. | 1. There is no safety threat and user should stop using battery. 2. Check if hybrid inverter and battery communication terminal is well connected. 3. If hybrid inverter and PACK cannot communicate when the communication wire is confirmed well connected, user should contact installer to repair battery. |

Technical Specifications7

7.1 ARK XH-A1(high voltage system)

| | | | |
|------------------|-------------------------------------|--|---|
| | Interior CAN Communication failure | Communication loss between two parallel | 1.Check whether the communication line between the battery pack and the battery pack is connected OK; 2.Check whether the communication line between the High voltage controller and the battery pack is connected OK. |
| | High temperature protection | The temperature exceeds the bms protection value | It is dangerous, please stop using the battery immediately, wait for the battery temperature to drop, the fault will be automatically resolved. |
| | Low temperature protection | The temperature is below the protection value | No safety risk, wait for the temperature to rise, the fault will be automatically resolved. |
| ● (ALM Light on) | Discharge short circuit | External short circuit of battery system | There is safety risk and user should stop using battery User should contact installer to repair PCS and battery. |
| | Precharger short circuit | | |
| | Precharger overtime circuit | | |
| | Voltage sampling anomaly protection | BMS Voltage sampling failure | There is safety risk and user should stop using battery. User should contact installer to repair battery. |
| | Current sampling fault | BMS current sampling failure | |
| | Main circuit fault | BMS main power circuit failure | There is safety risk and user should stop using battery. User should contact installer to repair battery. |
| | EEPROM fault protection | BMS MCU fail to get data from EEPROM | There is safety risk and user should stop using battery. User should contact installer to repair battery. |
| | Chip fault protection | Communication loss between two MCU | There is safety risk and user should stop using battery. User should contact installer to repair battery. |

| System Model | ARK 5.1XH-A1 | ARK 7.6XH-A1 | ARK 10.2XH-A1 | ARK 12.8XH-A1 | ARK 15.3XH-A1 |
|-------------------------------------|--|--------------------|---------------------|--------------------|---------------------|
| High Voltage Controller Model | BDC 95045-A1 | | | | |
| Number of power modules | 1 | | | | |
| Battery module | ARK 2.5H-A1 (2.56kWh,51.2V,28kg) | | | | |
| Battery module energy | 2.56kWh | | | | |
| Number of Modules in Series | 2 | 3 | 4 | 5 | 6 |
| Nominal energy | 5.12kWh | 7.68kWh | 10.24kWh | 12.8kWh | 15.36kWh |
| Max. output power | 2.5kW | 3.75kW | 5kW | 6.25kW | 7.5kW |
| Peak output power | 5kW,10s | 7.5kW,10s | 10kW,10s | 12.5kW,10s | 15kW,10s |
| Dimension (W*D*H) ^① | 650 * 260 * 630 mm | 650 * 260 * 815 mm | 650 * 260 * 1000 mm | 650 * 260 * 1185mm | 650 * 260 * 1370 mm |
| Weight ^② | 71kg | 99kg | 127kg | 155kg | 183kg |
| Module Nominal Voltage ^③ | 102.4V | 153.6V | 204.8V | 256V | 307.2V |
| Nominal voltage ^④ | 400V | 400V/650V | 400V/650V | 400V/650V | 400V/650V |
| Operating voltage range | 360V~550V | 360V~950V | 360V~950V | 360V~950V | 360V~950V |
| Battery type | Cobalt Free Lithium Iron Phosphate (LFP) | | | | |
| Ingress Protection | IP65 | | | | |
| Installation | Wall-mounted or Floor installation | | | | |
| Altitude | ≤2000m | | | | |
| Operating ambient temperature | - 10 C ~50 C | | | | |
| Relative humidity | 5%~95% | | | | |
| Cooling | Natural | | | | |
| Warranty | 10 years | | | | |
| Display | LED indicator | | | | |
| Battery System | Secondary Li-ion Battery System | | | | |

Note :

① The size does not include the base. When configuring more than 8PCS battery Modules, it is recommended to place them in two groups to avoid stacking too high and inconvenient installation.

② When choosing wall-mounted installation, you need to ensure that the installation wall can bear the weight of the battery system. We recommend floor stacking installation.

③ This Nominal Voltage refer to the Module side Voltage(battery packs Voltage after series).

④ Single phase power conversion system allows 2-7PCS battery modules in series, its nominal voltage is 400V;three phase power conversion system allows 3-10PCS battery modules in series, its nominal voltage is 650V.

| System Model | ARK 17.9XH-A1 | ARK 20.4XH-A1 | ARK 23.0XH-A1 | ARK 25.6XH-A1 |
|------------------------------------|--|---------------------|---------------------|---------------------|
| High Voltage Controller Model | BDC 95045-A1 | | | |
| Number of power modules | 1 | | | |
| Battery module | ARK 2.5H-A1 (2.56kWh,51.2V,28kg) | | | |
| Battery module energy | 2.56kWh | | | |
| Number of Modules in Series | 7 | 8 | 9 | 10 |
| Nominal energy | 17.92kWh | 20.48kWh | 23.04kWh | 25.6kWh |
| Max. output power | 8.75kW | 10kW | 11.25kW | 12.5kW |
| Peak output power | 17.5kW,10s | 20kW,10s | 22.5kW,10s | 25kW,10s |
| Dimension (W*D*H) ^① | 650 * 260 * 1555 mm | 650 * 260 * 1740 mm | 650 * 260 * 1925 mm | 650 * 260 * 2110 mm |
| Weight ^② | 211kg | 239kg | 267kg | 295kg |
| Module Nomial Voltage ^③ | 358.4V | 409.6V | 460.8V | 512V |
| Nominal voltage ^④ | 400V/650V | 650V | 650V | 650V |
| Operating voltage range | 400V~950V | 550V~950V | 580V~950V | 640V~950V |
| Battery type | Cobalt Free Lithium Iron Phosphate (LFP) | | | |
| Ingress Protection | IP65 | | | |
| Installation | Wall-mounted or Floor installation | | | |
| Altitude | ≤2000m | | | |
| Operating ambient temperature | -10℃~50℃ | | | |
| Relative humidity | 5%~95% | | | |
| Cooling | Natural | | | |
| Warranty | 10 years | | | |
| Display | LED indicator | | | |
| Battery System | Secondary Li-ion Battery System | | | |

Note:

① The size does not include the base. When configuring more than 8PCS battery Modules, it is recommended to place them in two groups to avoid stacking too high and inconvenient installation.

② When choosing wall-mounted installation, you need to ensure that the installation wall can bear the weight of the battery system. We recommend floor stacking installation.

③ This Nominal Voltage refer to the Module side Voltage(battery packs Voltage after series).

④ Single phase power conversion system allows 2-7PCS battery modules in series, its nominal voltage is 400V;Three phase power conversion system allows 3-10PCS battery modules in series, its nominal voltage is 650V.

7.2 BDC 95045-A1 (High voltage controller)

| No. | Items | Specification |
|-----|-----------------------------|------------------------|
| 1 | Model | BDC 95045-A1 |
| 2 | BAT voltage range | 90V-568V |
| 3 | Power module output voltage | 360V-950V ^① |
| 4 | Maximum current | 21A |
| 5 | peak current | 41A,10s |
| 6 | temperature range | -10~50℃ |
| 7 | IP rating | IP65 |
| 8 | Warranty | ≥10 years |
| 9 | communication method | CAN2.0,RS485 |
| 10 | Dimensions (W/D/H) | 650*260*265 mm ±2mm |
| 11 | Weight | 15±1kg |
| 12 | Certification | CE-EMC |
| 13 | Environmental requirements | RoHS |

Note:

①The actual operating voltage range depends on the matched hybrid inverter system

7.3 ARK 2.5H-A1(battery pack)

| No. | Items | Specification |
|-----|------------------------------|---|
| 1 | Battery pack Module | ARK 2.5H-A1 |
| 2 | Nominal Capacity/Energy | 50Ah/2.56kWh |
| 3 | Rated/Usable Capacity/Energy | 45Ah/2.3 kWh |
| 4 | Rated Voltage | 51.2V |
| 5 | Operating Voltage | 47.2 - 56.8V |
| 6 | Rated current(25℃) | 25A |
| 7 | Maximum current(25℃) | 50A |
| 8 | Battery Type | Cobalt Free Lithium Iron Phosphate (LFP) |
| 9 | Operative temperature range | -10~50℃ |
| 10 | Storage conditions | -30℃~50℃/7 days; -20℃~45℃/6 months; 95%RH |
| 11 | Cooling | Natural cooling |
| 12 | Dimension (W/D/H) | 650/260/184mm±2mm |
| 13 | Weight | 27±1kg |
| 14 | Installation | Wall-mounted installation/floor standing installation |
| 15 | Warranty | 10 Years |
| 16 | Ingress protection | IP65 |
| 17 | Battery designation | IFpP/41/150/102/[1P16S]M/-10+50/90 |
| 18 | Cell safety certification | IEC62619/UL1642 |
| 19 | Safety certification | IEC62619/CE/RCM/CEC |
| 20 | Transportation test standard | UN38.3 |
| 21 | Environmental requirements | RoHS |

Method for calculating rated capacity:
 Rated capacity of the measured module: 45 Ah
 Number of modules connected in series: 2~10
 Calculated rated capacity (Ah) = 45 Ah * 1 = 45Ah

7.4 Battery System designation

| Model | Battery designation | Recommended charge instructions |
|---------------|---|---|
| ARK 5.1XH-A1 | IFpP/41/150/102/[(1P16S)2S] M/-10+50/90 | constant current 6A charging to 400V of DC/DC output(Module side voltage and current is limited by DC/ DC circuit) |
| ARK 7.6XH-A1 | IFpP/41/150/102/[(1P16S)3S] M/-10+50/90 | constant current 6A charging to 650V of DC/DC output(Module side voltage and current is limited by DC/ DC circuit) |
| ARK 10.2XH-A1 | IFpP/41/150/102/[(1P16S)4S] M/-10+50/90 | constant current 8A charging to 650V of DC/DC output(Module side voltage and current is limited by DC/ DC circuit) |
| ARK 12.8XH-A1 | IFpP/41/150/102/[(1P16S)5S] M/-10+50/90 | constant current 10A charging to 650V of DC/DC output(Module side voltage and current is limited by DC/ DC circuit) |
| ARK 15.3XH-A1 | IFpP/41/150/102/[(1P16S)6S] M/-10+50/90 | constant current 12A charging to 650V of DC/DC output(Module side voltage and current is limited by DC/ DC circuit) |
| ARK 17.9XH-A1 | IFpP/41/150/102/[(1P16S)7S] M/-10+50/90 | constant current 13A charging to 650V of DC/DC output(Module side voltage and current is limited by DC/ DC circuit) |
| ARK 20.4XH-A1 | IFpP/41/150/102/[(1P16S)8S] M/-10+50/90 | constant current 15A charging to 650V of DC/DC output(Module side voltage and current is limited by DC/ DC circuit) |
| ARK 23.0XH-A1 | IFpP/41/150/102/[(1P16S)9S] M/-10+50/90 | constant current 17A charging to 650V of DC/DC output(Module side voltage and current is limited by DC/ DC circuit) |
| ARK 25.6XH-A1 | IFpP/41/150/102/[(1P16S)10S] S]M/-10+50/90 | constant current 19A charging to 650V of DC/DC output(Module side voltage and current is limited by DC/ DC circuit) |

LED indication Control Mechanism

| LED light definition | | | | | | | |
|----------------------|---|--|---------|---------|---------|---------|---|
| Status | Items | SOC indication | | | | RUN/ALM | Remark |
| | | LED1 | LED2 | LED3 | LED4 | LED5 | |
| Charge SOC | 0%-25% | ✱(t=1S) | | | | ● | RUN/ALM light on and one SOC lights flicker |
| | 26%-50% | ● | ✱(t=1S) | | | ● | |
| | 51%-75% | ● | ● | ✱(t=1S) | | ● | |
| | 76%-99% | ● | ● | ● | ✱(t=1S) | ● | |
| | 100% | ● | ● | ● | ● | ● | |
| Discharge SOC | 100%-76% | ● | ● | ● | ● | ● | |
| | 75%-51% | ● | ● | ● | | ● | |
| | 50%-26% | ● | ● | | | ● | |
| | 25%-5% | ● | | | | ● | |
| | 5%-0% | ● | | | | ✱(t=1S) | RUN/ALM light flicker |
| Idle | 100%-76% | ● | ● | ● | ● | ● | |
| | 75%-51% | ● | ● | ● | | ● | |
| | 50%-26% | ● | ● | | | ● | |
| | 25%-5% | ● | | | | ● | |
| | 5%-0% | ● | | | | ✱(t=1S) | RUN/ALM light flicker |
| Protection | Cell charge overvoltage alarm | SOC indicates current remaining capacity | | | | ✱(t=1S) | RUN/ALM light flicker green |
| | Cell charge overvoltage protection | | | | | ✱(t=1S) | RUN/ALM light flicker green |
| | Charge total voltage overvoltage alarm | | | | | ✱(t=1S) | RUN/ALM light flicker green |
| | Charge total voltage overvoltage protection | | | | | ✱(t=1S) | RUN/ALM light flicker green |
| | Charge and discharge over current alarm | | | | | ✱(t=1S) | RUN/ALM light flicker green |

| | | | | |
|------------|---|--|---------|-----------------------------|
| Protection | Charge and discharge over current protection | | ✱(t=1S) | RUN/ALM light flicker green |
| | Charge and discharge over current hardware protection | | ✱(t=1S) | RUN/ALM light flicker green |
| | Charge and discharge high temperature alarm | | ✱(t=1S) | RUN/ALM light flicker green |
| | Charge and discharge high temperature protection | | ✱(t=1S) | RUN/ALM light flicker green |
| | Charge and discharge low temperature alarm | | ✱(t=1S) | RUN/ALM light flicker green |
| | Charge and discharge low temperature protection | | ✱(t=1S) | RUN/ALM light flicker green |
| | Cell discharge Under-voltage alarm | | ✱(t=1S) | RUN/ALM light flicker green |
| | Cell discharge under voltage protection | | ✱(t=1S) | RUN/ALM light flicker green |
| | Discharge total voltage under voltage alarm | | ✱(t=1S) | RUN/ALM light flicker green |
| | Discharge total voltage under voltage protection | | ✱(t=1S) | RUN/ALM light flicker green |

| | | | | |
|------------|---|--|---------|-----------------------------|
| Protection | Charge and discharge Over current hardware protection | SOC indicates current remaining capacity | ✱(t=1S) | RUN/ALM light flicker green |
| | Ambient temperature over-temperature alarm | | ✱(t=1S) | RUN/ALM light flicker green |
| | Ambient temperature over-temperature protection | | ✱(t=1S) | RUN/ALM light flicker green |
| | Cell voltage difference is too large alarm | | ✱(t=1S) | RUN/ALM light flicker green |
| | Cell voltage difference is too large protection | | ✱(t=1S) | RUN/ALM light flicker green |
| | Cell temperature difference is too large alarm | | ✱(t=1S) | RUN/ALM light flicker green |
| | Cell temperature difference is too large protection | | ✱(t=1S) | RUN/ALM light flicker green |
| | Cell rapid over voltage protection | | ✱(t=1S) | RUN/ALM light flicker green |
| | Battery pack over voltage alarm | | ✱(t=1S) | RUN/ALM light flicker green |
| | Battery pack over voltage protection | | ✱(t=1S) | RUN/ALM light flicker green |
| | Battery pack under voltage alarm | | ✱(t=1S) | RUN/ALM light flicker green |
| | Battery pack under voltage protection | | ✱(t=1S) | RUN/ALM light flicker green |

| | | | | |
|------------------------------------|--|--|---------|-----------------------------|
| Protection | Low temperature charging current limit non-response protection | | ✱(t=1S) | RUN/ALM light flicker green |
| Fault, personnel handling required | Precharged short circuit | SOC indicates current remaining capacity | ✱(t=1S) | RUN/ALM light flicker red |
| | Precharged overtime circuit | | ✱(t=1S) | RUN/ALM light flicker red |
| | Interior CAN communication failure | | ✱(t=1S) | RUN/ALM light flicker red |
| | Insulation fault alarm | | ✱(t=1S) | RUN/ALM light flicker red |
| | UART communication timeout alarm | | ✱(t=1S) | RUN/ALM light flicker red |
| | Communication timeout alarm with hybrid inverter | | ✱(t=1S) | RUN/ALM light flicker red |
| | Abnormal output port voltage | | ✱(t=1S) | RUN/ALM light flicker red |
| | BMU encoding timeout | | ✱(t=1S) | RUN/ALM light flicker red |
| | Cell failure protection | | ●(t=1S) | RUN/ALM light flicker red |
| | Main circuit failure protection | | ●(t=1S) | RUN/ALM light flicker red |
| | EEPROM fault protection | | ●(t=1S) | RUN/ALM light flicker red |
| | Front-end chip failure protection | | ●(t=1S) | RUN/ALM light flicker red |
| | EEPROM calibration parameter failure | | ●(t=1S) | RUN/ALM light flicker red |

| | | | | |
|------------------------------------|---|--|---------|-------------------------|
| Fault, personnel handling required | Current sampling failure | SOC indicates current remaining capacity | ●(t=1S) | RUN/ALM light stays red |
| | Total voltage sampling failure | | ●(t=1S) | RUN/ALM light stays red |
| | The motherboard power supply is abnormal | | ●(t=1S) | RUN/ALM light stays red |
| | Insulation resistance protection | | ●(t=1S) | RUN/ALM light stays red |
| | Hardware reference voltage abnormal failure | | ●(t=1S) | RUN/ALM light stays red |

Shenzhen Growatt New Energy Co., Ltd

4-13/F, Building A, Sino-German(Europe) Industrial Park, Hangcheng Ave, Bao'an District, Shenzhen, China

T +86 755 2747 1942

E service@ginverter.com

W www.ginverter.com